



motus
is movement



motus is movement

Motus is a family of Luxo luminaires with unique design features and excellent light output. The collection includes task lights, wall, freestanding and pendant luminaires. A family of luminaires makes it easy to meet different needs with products of the same design.

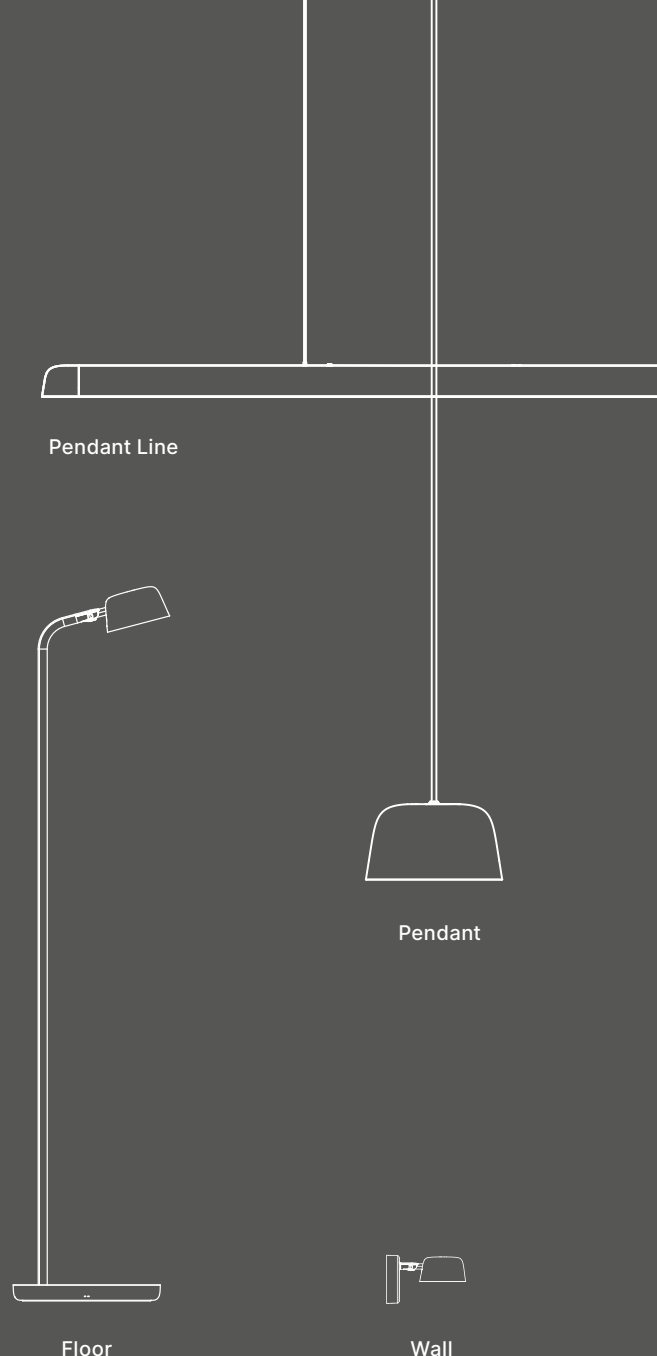
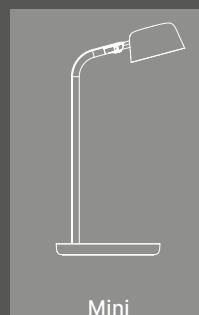
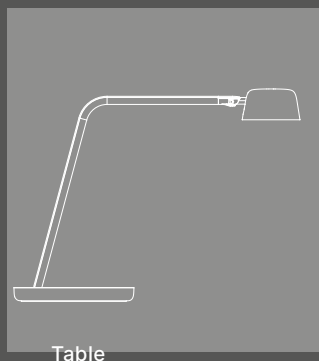
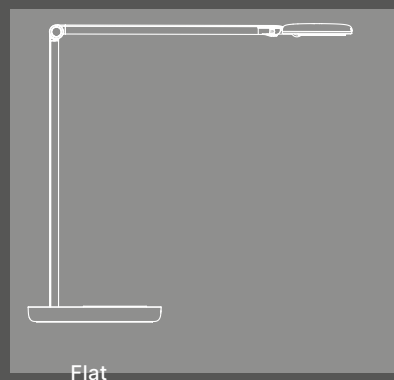



The name Motus is Latin and means “movement”. The Motus luminaires have functionality that resembles that of the human body, and which makes it easy to position the light exactly where it is needed. This flexibility makes Motus an excellent choice for a wide range of applications.

Inspiration from an aircraft

The ability to place the light exactly where it is needed is a hallmark of a Luxo luminaire. Of particular importance is the flexibility of the lamp head. The Motus luminaires have a joint between the lamp head and arm that allows for maximum freedom of movement. This was inspired by the movements of an aircraft:

An aircraft has three dimensions of movement, known as pitch, roll and yaw. Motus imitates these movements, allowing for horizontal side-to-side movements (yaw), up and down movement (pitch) and rotation around a horizontal axis (roll). Motus offers all of these movements in one joint. There are no screws to tighten, no knobs to turn.

Contemporary design

The Motus luminaires have a sleek Scandinavian design. These are friendly forms to live with; an invitation to touch and feel the product. The luminaires are powder-coated with a matt finish, adding to the stylish look and feel. The various versions are all made to match the design of the other members of the family, making it easy to combine several Motus luminaires in one lighting solution.





Motus Flat is available in the Luxo Colour Concept upon request.

Luxo Colour Concept

The Motus luminaires are offered in black or white, and are also available in a selection of colours from the Luxo Colour Concept. The Luxo Colour Concept is a selection of colours developed in cooperation with independent designers. They aim to reflect popular trends in home and office environments and will change as the trends are changing.

The current collection is inspired by the natural colours found along the Scandinavian coastline. Hues of green, teal and citrus are trendy, inspired by Nature, and will fit very well with contemporary building projects.



Black



White



Estate Green



Pleasant Green



Silk Teal



Mild Citrus

Excellent light output

The Motus luminaires are equipped with the latest LED light technology, offering light with a pleasant colour temperature and excellent colour rendering capabilities.

A high lumen output which is dimmable as standard makes it suit whichever light level demands a user might have. This also makes it possible to change the ambience of a room from neutral to relaxed and social.

Motus is available with Dim 2 Warm technology. When dimming down the lamp the colour temperature changes to a warmer white light, creating an intimate ambience. When turning the full light on again, the light reverts to the standard clear white.

Motus is also available with tuneable white functionality, this means that the colour temperature can be changed from a cool white to warm white in different steps. The colour temperature can for example be changed depending on time of the day and amount of daylight, cooler in morning and warmer light in the evening.

Objects and materials are also presented in different ways depending on the colour temperature of the light.





Motus Table

This versatile task light has an arm with two joints, including the very flexible neck joint between lamp head and arm. This means the light can be directed exactly where you need it without moving the lamp.

The lamp head is cup-shaped and provides bright clear light, suitable for all work tasks. Motus Table has excellent symmetric light output. The design will make this task light stand out on any table or work desk.

Mounting options

Motus Table can be mounted on a table base. It can also be inserted into the table top with a purpose-made table insert bracket, fastened to the desk with a table edge clamp or be mounted on a wall with a special wall bracket.

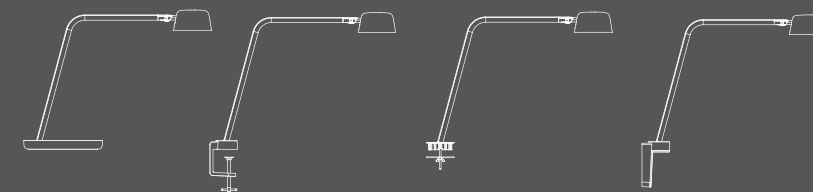

Motus Flat

This version of Motus has a longer arm, with three joints which makes placement of the head effortless in every direction. The ingenious spring system has an everlasting balancing effect that makes the arms and head always stay in whatever position it's placed without ever needing to be tightened.

The lamp head is flat, with asymmetric light output. This means that the light is directed forward from the lamp onto the desk space in front of you. This gives a comfortable work space without reflections.

A lumen output which is dimmable as standard makes it suit whichever light level demands a user might have.

Mounting options

Motus Flat can be mounted on a table base or fastened to the desk with a table edge clamp. It can also be inserted into the table top with a purpose-made table insert bracket, or be mounted on a wall with a special wall bracket.

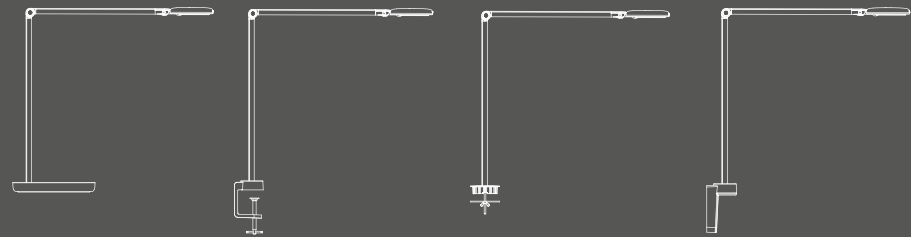



Available with motion sensor

As an option, Motus Flat is available with a built-in motion sensor. The sensor turns the task light on when motion is detected, and turns it off after a period of inactivity.



Available with adjustable colour temperature

Motus Flat is available with tuneable white functionality. Touch the switch, and the light changes from warm white to cool white in three effortless steps, from 2700K to 3300K to 4000K.



Available with inductive charging

As an option, Motus Table and Motus Flat are offered with a table base with a built-in inductive charger. Wireless works with most modern smart phones on the market today. Just place your mobile phone on the electromagnetic field in the table base.





Motus Mini

Motus mini is a small version of Motus Table. A short arm is fixed to a table base. The cup-shaped lamp head is fastened to the arm with the same flexible joint as Motus Table, making it easy to position the light exactly where you need it. In spite of its modest size, Motus Mini boasts generous light output, making it a complete task light for smaller work areas.

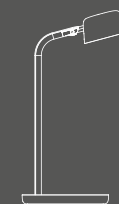

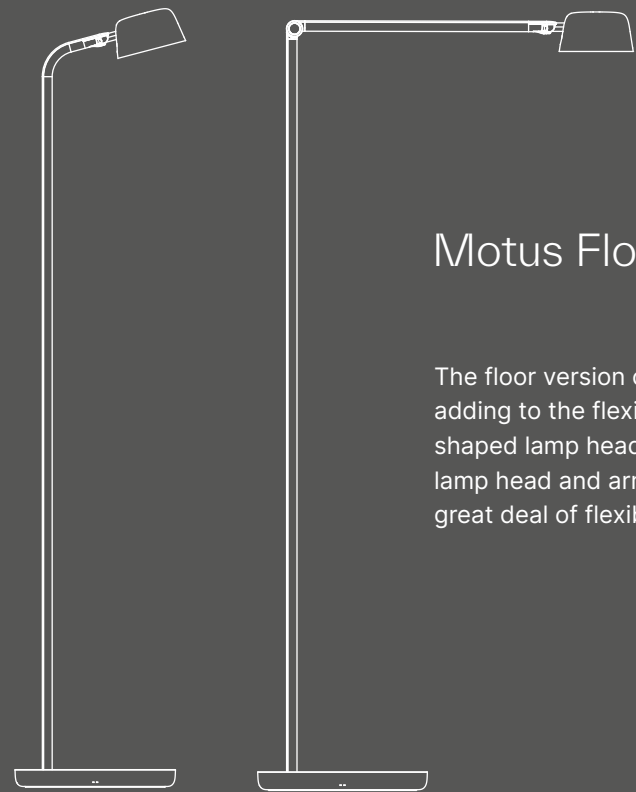

Motus Floor

The floor version comes with a choice of arm. It is available with one or two joints, adding to the flexibility of the luminaire. Both versions have the characteristic cup-shaped lamp head, with symmetric light output and the same flexible joint between lamp head and arm. Freestanding luminaires are easy to move around, offering a great deal of flexibility when arranging the lighting scheme in a room.





Motus Wall

The wall version of Motus will work well as a bed head lamp, or as accent lighting in a corridor. The flexibility of the joint between lamp head and arm makes it easy to position the light where it is needed. Motus Wall have the characteristic cup-shaped lamp head, with symmetric light output.



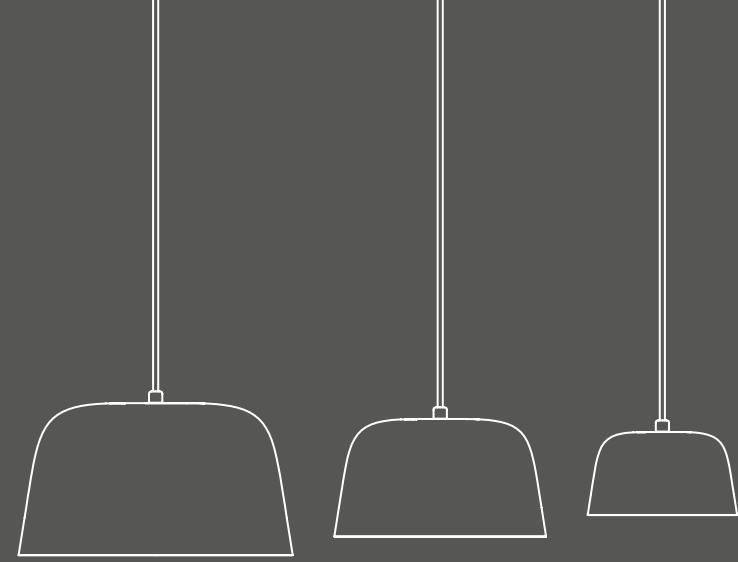

Motus Pendant

A selection of pendant luminaires complements the Motus family. The pendants are available in three different sizes, large, medium and small, and will fit in with most projects. They are suitable for mounting over a table or in a cluster over a seating group in a lounge or any other social area. Although of modest size, the light output is excellent, making Motus Pendant more than just a decorative element in the room.



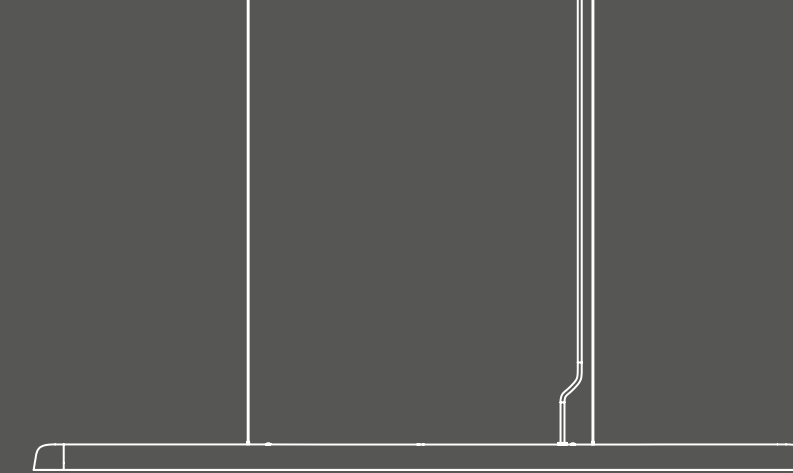

Motus Line

Motus Line is a pendant luminaire designed for mounting directly above your head at your workstation. Like the other members of the Motus family it has a sleek Scandinavian design. Motus Line is molded from one piece, with a monolithic shape devoid of cuts and irregularities. A high efficacy combined with excellent glare control and impeccable lighting uniformity on the working surface are among the features that allow this luminaire to fulfil the highest expectations in terms of performance in addition to providing exquisite aesthetics.



Motus Line makes the adjustment of light for each individual workplace an easy task. Equipped with two infrared switches you can set the light level to your personal preference for both the indirect and direct light by giving the switches a light touch.



reddot winner 2021

Award winning design

The internationally acclaimed “Red Dot” is one of the most sought-after seals of quality and good design.

In 2021, Luxo Motus was awarded the Red Dot award for product design. The jury stated; “Due to a focus on ergonomics, the Motus lighting range achieves a high quality of use and lighting comfort”.

Design: Andreas Murray
and Hans Bleken Rud



Andreas Murray



Hans Bleken Rud

Andreas Murray, Permafrost

Permafrost was founded in 2000 by four Norwegian industrial designers: Andreas Murray, Eivind Halseth, Oskar Johansen and Tore Vinje Brustad. From their design studio in Oslo, Norway they serve clients from all over the world.

Permafrost`s ultimate goal is to create timeless, lasting products that the users will love and take care of. As a result, Permafrost`s work is all about designs that are user friendly, simple and safe, with just enough personality to make them stand out.

Hans Bleken Rud, Glamox

Hans Bleken Rud is a Norwegian industrial designer. He began his studies at the Art & Design College, and later graduated with a Masters in Industrial Design from the Oslo School of Architecture and Design. His career has mostly been focused towards various projects related to lighting and light design. He has also designed products for the sports, aid and aviation industries. Since 2007 he has worked as a professional designer for Glamox.

About Motus

Motus is all about focusing the light where you want it. With its logical structure and friendly nature, it invites individual adaptations to the user`s own needs. When the lamp is switched on, an intimate atmosphere is created, while the work tasks comes into focus. The product series is the result of a thorough process, in which highly functional products are given a comfortable and elegant appearance with carefully worked surface and details.

motus - variants

○ joint

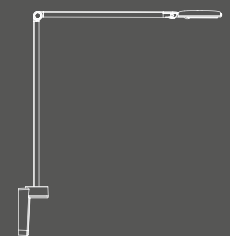
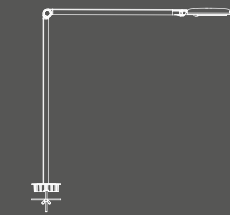
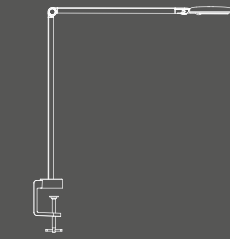
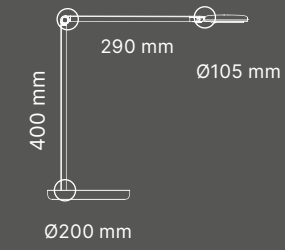

Flat

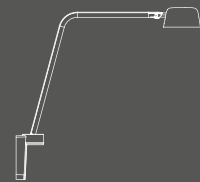
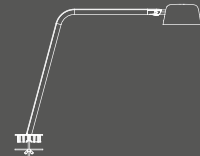
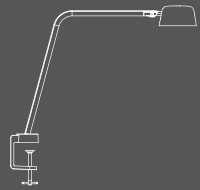
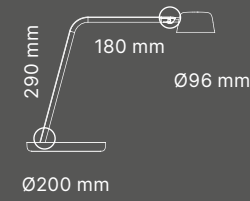

Table

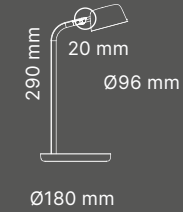

Mini

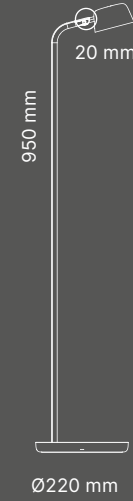

Floor



Wall

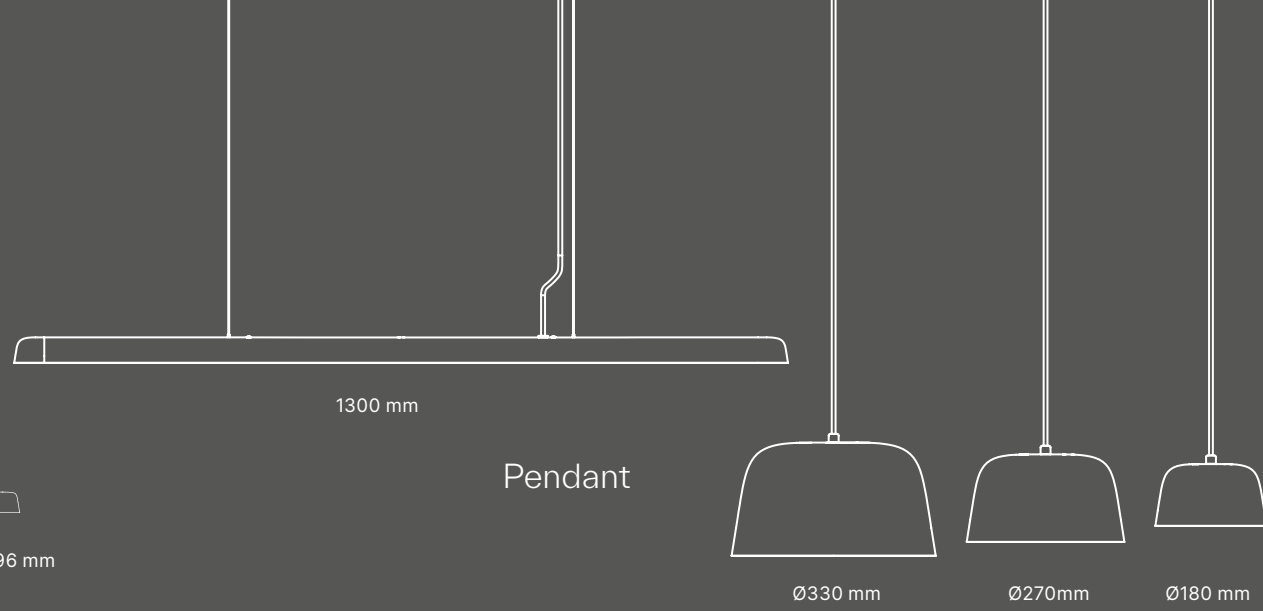

Pendant





motus
is movement

